

**RAPA**

REFRIGERATION DEVICES MANUFACTURER

L-WB1

# REFRIGERATED ISLAND



[www.rapa.pl/en](http://www.rapa.pl/en)

RAPA sp. j.  
9 Ceramiczna Street  
20-149 Lublin, Poland

+48 81 718 46 51  
rapa@rapa.lublin.pl

## Boost your sales in self-service mode

Are you carefully planning the customer's path and want the products to be at their fingertips? Provide unlimited access to the products with refrigerated island, that we have designed for safe and flexible shopping.



You will easily display all of the products, because we have made **the sides out of transparent materials**, that do not limit visibility.

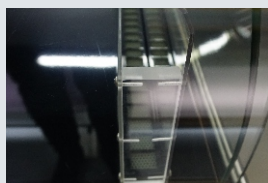

You will take care of the environment, because the device uses the **R-290** refrigerant.

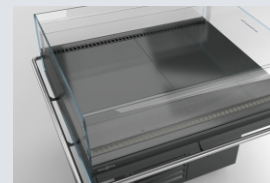

You can easily create attractive exhibition, because the products are available from **all 4 sides**.



Go ahead and plan commercial space, due to the **stainless steel buffers**, the island can be placed safely even in very busy shopping aisles.

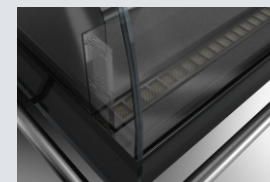

You will provide fresh products, due to **dynamic cooling**.

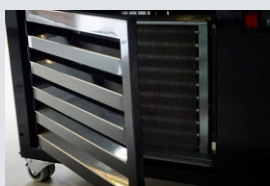

You will easily clean the condenser, because the access to it does not require use of tools.



You will easily set up the best temperature, because we have installed a **temperature controller with clear display**.



You can easily set the device in any place because we have mounted **4 wheels (2 of them have brakes)**.

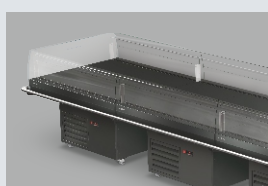

You will increase the exhibition space, because you can **connect the islands in series lines**.



You will match the island to every interior, because we have prepared **several colours** that you can choose from.

## STANDARD EQUIPMENT

### Refrigerated unit

- 3rd climatic class
- Plug-in unit powered with ecological R-290 refrigerant
- Fan assisted cooling
- Electronic temperature controller with display
- Undemanding tools access to cleaning the condenser

### Housing

- Set of 4 pcs. of rotary wheels (2 with brake)
- Housing and exposition painted in color: RAL 9003 Signal white , RAL 7004 Signal grey or RAL 9005 Jet black - gloss
- Freestanding device with possibility of connecting it in series lines
- Protective bumpers made of stainless steel

### Exposition

- Well visible exposition of goods
- Divided bottom of the exposition made of stainless steel, pulled out segments
- Maximum exposition load - 110 kg for evenly placed goods
- Possibility to change the angle of the exposition tilt - 3 tilt angles
- Device glazed from all sides 2 sides made of tempered glass, 2 sides made of transparent plexiglass

## ADDITIONAL EQUIPMENT

### Refrigerated unit

- Protection of the evaporator with a preservative coating
- Automatic condensate evaporation system

### Housing and exposition

- Painting the device in colour: RAL 7015 Slate grey, RAL 5002 Ultramarine blue, RAL 6017 May green, RAL 1021 Rape yellow, RAL 3020 Traffic red or RAL 8016 Mahogany brown
- Stainless steel interior

## ACCESSORIES

- Pollen filter
- USB temperature recorder

## TECHNICAL DATA

climatic class	3
temperatures range	+4°C ÷ +10°C
refrigerant (HC)	R-290
rated voltage	230 V~ / 50 Hz
rated power	490 W
defrosting	automatic

### freestanding device

length [cm]	141
depth [cm]	127
height [cm]	96
exposition length [cm]	125
exposition depth [cm]	90
exposition height [cm]	12

### modules to be connected in lines

sides length [cm]	125
-------------------	-----

## COLOURS

Standard

Additional equipment

housing & exposition



exposition

stainless steel

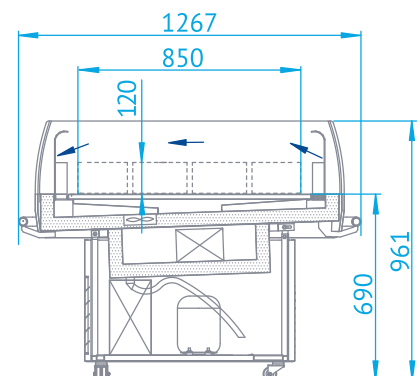
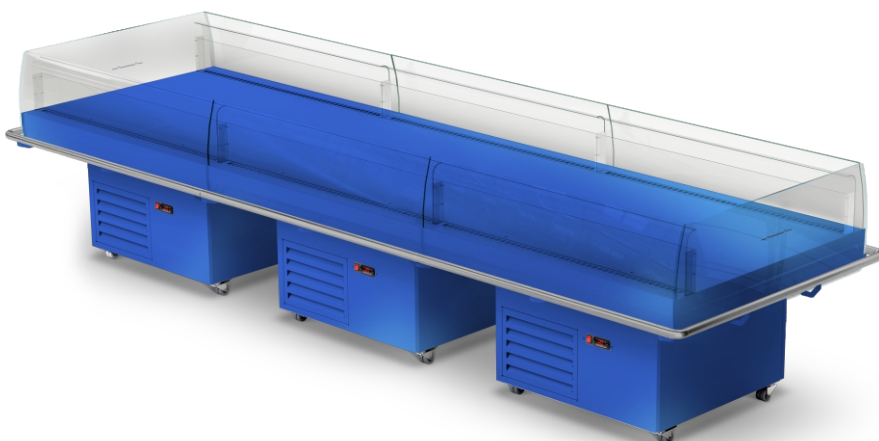

### Example finish

Housing and exposition: RAL 5002 Ultramarine blue